

E2710 | TOP UNLOADING ARM WITH HEATING LANCE FOR RAIL CARS



FEATURES

- * Petroleum application
- * Reliable
- * Safe
- * Easy handling
- * Long life
- * Low maintenance
- * Various materials
- * EMCO-high performance swivel joints

This type of loading arm is especially designed to heat up and unload „frozen“ products. It is suitable for the top loading of Rail tankers.

Because of the robust and high quality design of the swivel joints and the precise loading arm balancing, the handling of the loading arm is very convenient.

E2710

E2710 | TOP UNLOADING ARM WITH HEATING LANCE FOR RAIL CARS

TECHNICAL DATA E2710

Size DN		Seals	Temperature range	Accessories
Suction tube	Heating tube			
100	50/80	FVMQ, PTFE, special materials	* High temperature from -40 °C up to 200 °C	* Cover plate * Support bracket

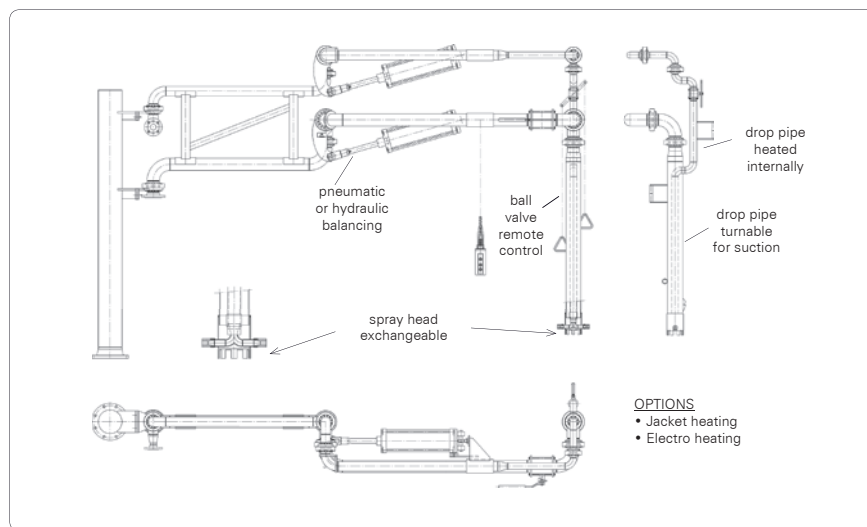

By unloading through the nozzles at the end of the drop pipe hot product will be sprayed into the vessel. Thereby the „frozen“ product in the vessel will be warmed up and can be sucked off through the product pipe. The drop pipe is turnable so that the whole vessel can be reached with hot product.

It is possible to fasten a movable holding bar (covering plate) for a level controller. The up and down movement of the A-length is provided by a pneumatic or hydraulic cylinder.

TYPICAL APPLICATION:

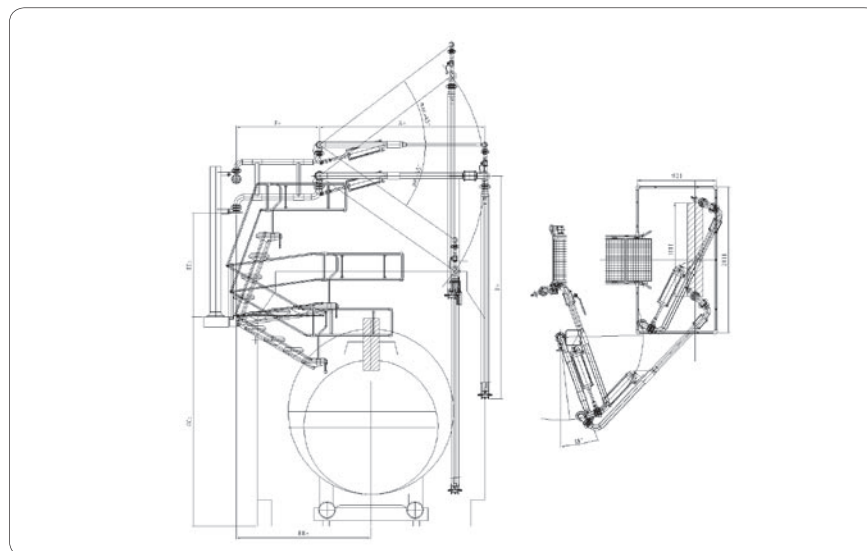

EMCO WHEATON carbon steel swivel joint with flame hardened ball race way for a long life time! For more details see our data sheet D2000 Swivel Joint.

Better by
Design



EMCO WHEATON

A Gardner Denver Product

EMCO WHEATON GmbH
Emcostraße 2-4 · 35274 Kirchhain · Germany
Phone +49 6422 84-0 · Fax +49 6422 5100
www.emcowheaton.com · info-de@emcowheaton.com