

E2704 WITH INTERNAL HEATING LANCE BOTTOM LOADING ARM

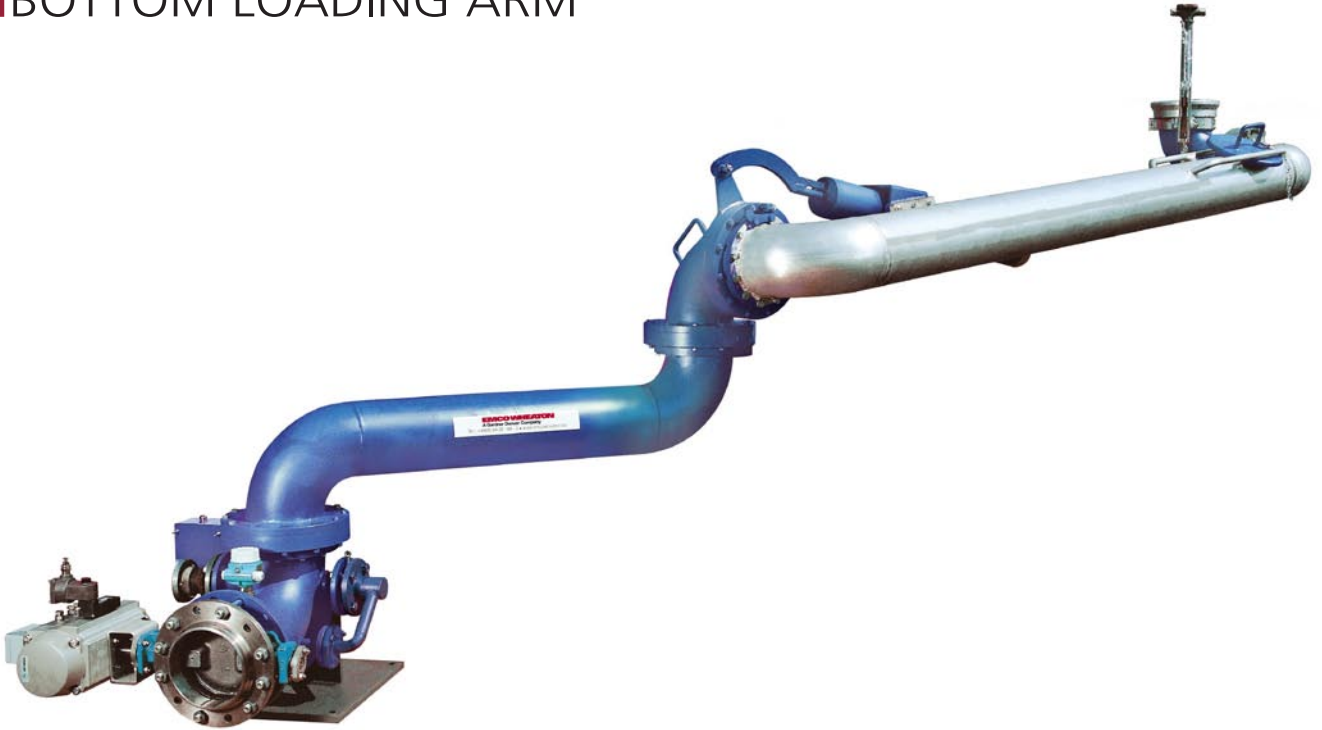

FEATURES

- * Petroleum applications
- * Reliable
- * Long life
- * Low maintenance
- * Easy handling
- * Environmentally friendly
- * Safe
- * Low cost

This loading arm is designed for applications to handle products with a high density. The loading arm is equipped with a special coupler for unloading of russian railcar from underneath. The coupler enables a safe and quick connection independent to the orientation of the adapter lid.

The long reach of the loading arm also enables connection to rail cars when the adapter is not positioned exactly. Due to the low offset of the swivel joints a minimum vertically height is guaranteed.

The robust and high quality design of the swivel joints and the spring cylinder balancing gives comfortable and smooth handling of the arm.

E2704

E2704 WITH INTERNAL HEATING LANCE

BOTTOM LOADING ARM

DIMENSIONS AND TECHNICAL DATA

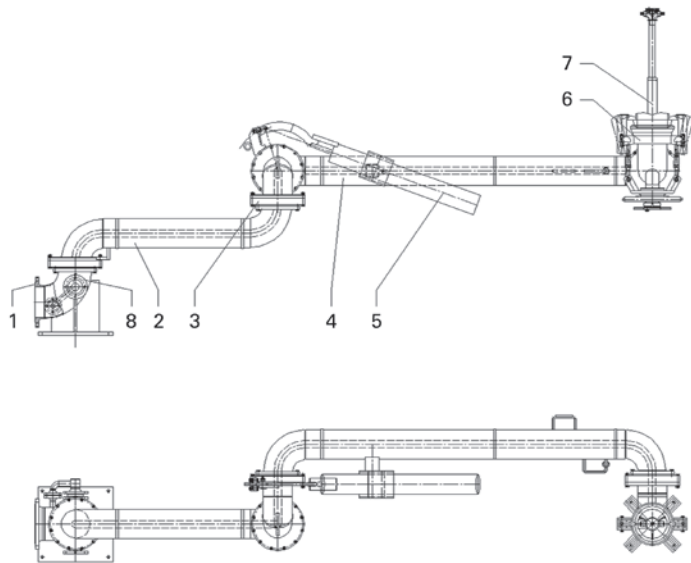

1. Inlet flange
2. "F"-arm
3. Swivel joint
4. "A"-arm
5. Spring cylinder
6. Coupler
7. Telescopic heating lance
8. Connection flange for internal heating

Hot product will be pumped through the internal heating line. Due to the inner pressure the telescope heating lance moves up, and the hot product will be sprayed through the spray head of the lance into the railcar. The hot product heats up the frozen (solidified) product, which then flows through product line of the loading arm.

MATERIALS AND TECHNICAL DATA

Sizes	Material	Seals	Temperature range
DN 200, DN 175 (product arm) DN 50, DN 40 (heating arm)	carbon steel	NBR, FPM, PTFE, special materials	-50 °C to +50 °C, higher or lower temperature on request

Alternative dimensions available on request.

ENVELOPE DRAWING

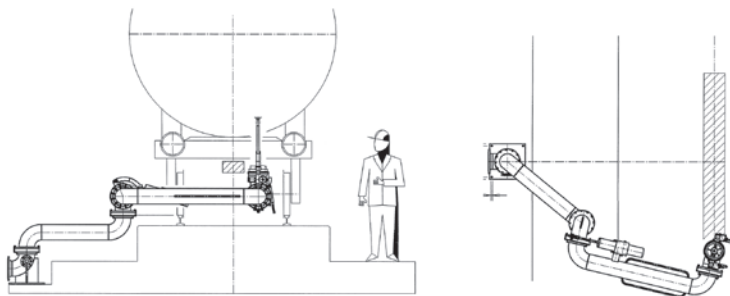

EMCOWHEATON carbon steel swivel joint with flame hardened ball race way for a long life time!

For more details see our data sheet swivel joint **D2000**.

EMCOWHEATON

A Gardner Denver Product

Better by
Design



EMCOWHEATON GmbH
Emcostraße 2-4 · 35274 Kirchhain · Germany
Phone +49 6422 84-0 · Fax +49 6422 5100
www.emcowheaton.com · info-de@emcowheaton.com