

OVERFILL PREVENTION DEVICE

ELECTRICAL OVERFILL PREVENTION DEVICE

The overfill prevention device is a secondary safety device which prevents a product overflow, e.g. in case of a wrongly pre-selected loading amount. The electrical signal of the overfill prevention device is

processed in the control system and can be used to shut off the loading process. If the control system does not exist already in the customer's terminal it can also be within EMCO WHEATON's scope.

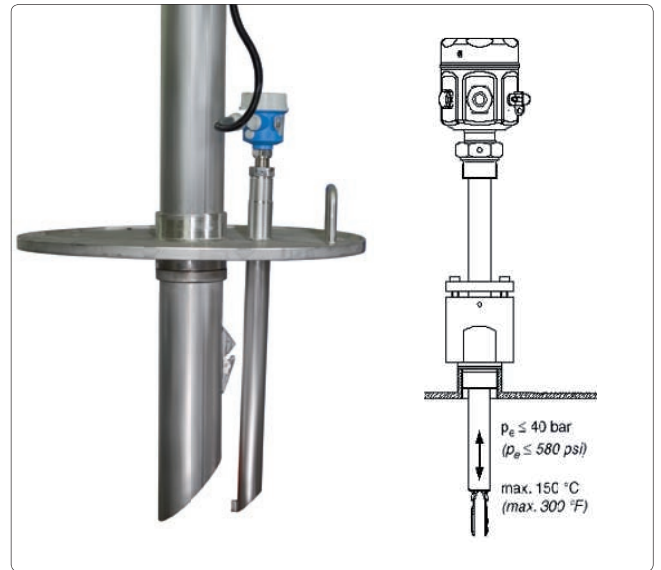

PRINCIPLE: CAPACITY

As the probe immerses into the fluid the capacity between the probe and the compartment wall changes and this is creating an electrical signal. In case of a coated compartment a double dipstick probe is required.

PRINCIPLE: OSCILLATION

The vibration of an oscillating fork is influenced as it immerses into the fluid. This is creating an electrical signal.

The system is approved in accordance with WHG, VbF and ATEX.

The system is approved in accordance with WHG and VbF.

APPLICATION

- * Highly aggressive products
- * Continuous measuring
- * Product temperatures from -80 °C up to +200 °C

APPLICATION

- * Products with standard viscosity
- * Marginal level indication
- * Product temperatures from -40 °C up to +300 °C

OVERFILL PREVENTION DEVICE

OVERFILL PREVENTION DEVICE

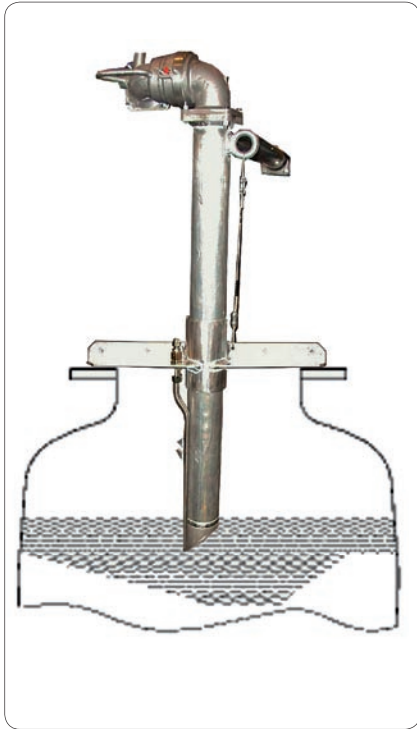

PNEUMATIC OVERFILL PREVENTION DEVICE

A low air or nitrogen stream flows through a dip tube into the compartment. When the rising fluid level reaches the dip tube the evolving back pressure is used as a signal.

A redundant version in accordance to WHG is available. In case of a closed loading process a second dip tube is required.

APPLICATION

- * Products with high viscosity
- * High temperatures
- * Marginal level indication
- * Product temperatures from -40 °C up to +280 °C

SPECIAL APPLICATIONS – LEVEL SENSORS

In special areas electric probes are used as level indicators within control systems. The created signals are used i.e. to trigger in incremental run-up or shutdown of pumps or a gradual valve shut off to reduce the product flow. A further application is to indicate the drain status of a loading arm.

EMCO WHEATON

A Gardner Denver Product

Better by Design



EMCO WHEATON GmbH
Emcostraße 2-4 · 35274 Kirchhain · Germany
Phone +49 6422 84-0 · Fax +49 6422 5100
www.emcowheaton.com · info-de@emcowheaton.com