

B0300 LNG/CNG | MARINE LOADING ARM



DESIGN FEATURES

- * Sizes from 4" up to 16"
- * Pressure ratings from PN 10 up to PN 150
- * Materials: carbon steel, low temperature steel, stainless steel
- * Temperature range: from -165 °C up to +200 °C
- * Customized solutions on request
- * EMCO high performance swivel joints

The B0300 marine loading arm has been designed for any kind of special application where it is essential to keep the product pipe consistently the same size for either economical or technical reasons, e.g. cryogenic products down to -165 °C, piggable systems and PTFE-lining. This design has proven its reliability for many years now.

The B0300 design includes a special support structure for the standpost, inboard and outboard arm and thus separating any mechanical loads imposed to the product pipe, except the dead-weight and internal pressure loads. Additionally this also provides the optimum in regard to operational safety aspects, low weight of the arm and lowest wind loads imposed to the jetty structure.

The balancing of the arm is achieved by a rigid link pantograph system with independent counterweights directly linked to the inboard- and outboard arm. Thus providing that accurate balance is definitely ensured throughout all maneuvering and connecting positions.

The advantages over hose loading facilities are ease of handling, higher availability/ flexibility, less man power and minimum maintenance required while providing maximal operational safety and minimized operational cost (cost of ownership).

The B0300 is designed for hydraulic operation and can be fitted with the most sophisticated ancillary equipment.

Additional equipment is available.

B0300

B0300 LNG/CNG | MARINE LOADING ARM

MATERIALS AND TECHNICAL DATA – INCL. EMERGENCY RELEASE SYSTEM

NB	A + B	X	C	D	N	S	Flow rate	Weight	Bending moment
	mm	mm	mm	mm	mm	mm	m ³ /h	kN	kNm
4"	5500	1000	8000	8000	900	4500	300	160	325
6"	5500	1000	8000	8000	1000	4500	600	165	338
8"	5500	1500	8000	8000	1350	4500	1100	190	368
10"	7000	1500	11000	9000	1750	6000	1700	360	729
12"	7000	1500	11000	10000	2100	6000	2500	395	759
16"	7000	2000	11000	11000	2400	6000	4000	490	870

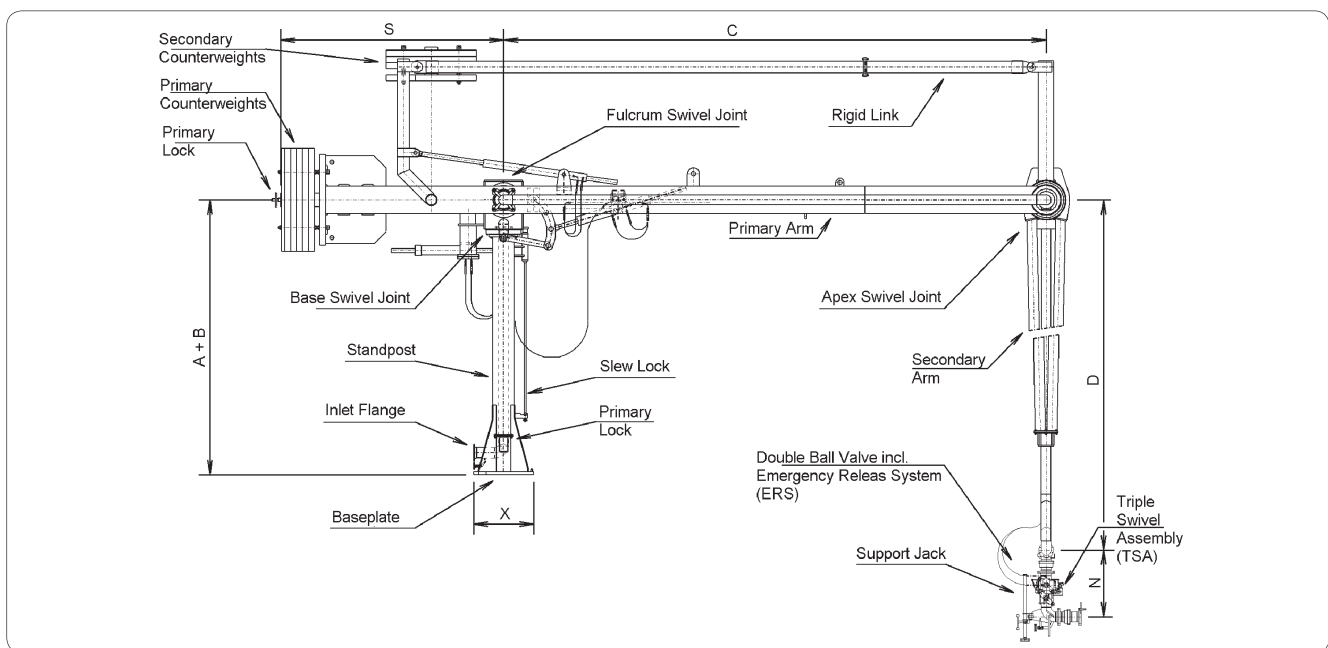

DESIGN

- * Fully balanced with independent counterweights for inboard and outboard arm
- * Special support frame to reduce imposed mechanical loads
- * Light weight design
- * Swivel joints either welded-in or flanged
- * For transfer of mineral oil, chemicals, liquefied gases and LNG/CNG
- * Seals available in Buna-N, Viton, PTFE or other specific materials
- * Piggable product pipe
- * Dedicated material for product pipe

ACCESSORIES

- * Range alarm system
- * Drainage connections
- * Emergency release system (ERS)
- * Hydraulic operation
- * Hydraulic or manual quick coupler
- * Insulation flange
- * Nitrogen purge line
- * Drain line
- * Vacuum breaker
- * Vapour return line

Better by Design



EMCOWHEATON

A Gardner Denver Product

EMCO WHEATON GmbH
Emcostraße 2-4 · 35274 Kirchhain · Germany
Phone +49 6422 84-0 · Fax +49 6422 5100
www.emcowheaton.com · info-de@emcowheaton.com